

Human Machine Interface with 10" TFT LCD display



【Introduction】

MT8000 series is the new HMI generation of Weintek. With the design concept of meeting customers' satisfaction while easy-to-Use attribute as before, a MT8000 not only performs as a Human Machine Interface but also plays as a role of data exchange center. Through the most popular Ethernet connection, data can be shared among MT8000s without limitation and any SCADA/HMI software on the PC can simply access data from MT8000s. MT8000 series is the best choice for your requirement tomorrow.

The MT8100i is equipped with a USB 1.1 host, a USB 2.0 high speed device and SD card slot.



- x **Construction:** plastic molding housing
- x **Display:** 10" 65,536 color TFT LCD
- x **CPU and core logic:** 32Bit RISC 400MHz processor
- x **DRAM:** 64 MB DDR2 on board
- x **Storage:** 128 MB flash memory on board,
(User project size: 16MB, Data and Event log size: 48MB)
- x **I/O:** 3 serial ports: Com1: RS-232/RS-485 2w/4w,
Com2: RS-232,
Com3: RS-232/RS-485 2w
1 Ethernet port (10/100Base-T)
1 USB 1.1 host
1 USB 2.0 high speed device
- x **Sound output:** Line out
- x **RTC:** Built-in
- x **Power input:** 24±20%V_{DC}, 300mA@24VDC
- x **Dimension (W x H x D):** 271 x 212 x 50mm
- x **Weight:** 1.4kg
- x **Software:** EB8000 V2.0.0 or later

◆ **Features**

- Z 10" 800x480 TFT LCD
- Z Fan-less cooling system
- Z Built-in flash memory and RTC
- Z NEMA4/IP65 compliant front panel
- Z LED Back Light
- Z One USB Host and one USB client port
- Z SD card slot
- Z Power Isolator inside

◆ **LCD**

Display type	TFT LCD
Display size (diagonal)	10"
Max colors	65536
Resolution	800 x 480
Viewing angle (°)	45/65/65/65(T/B/R/L)
Luminance (cd/m ²)	350
Backlight	LED
Backlight Life time	30,000 hrs.
Contrast ratio	300:1



- x **Type:** 4-wire, analog resistive
- x **Resolution:** continuous
- x **Light transmission:** above 80%
- x **Life:** 1 million activation minimum

◆ **Environmental**

- x **Operating temperature:** 0° ~ 45°C (32° ~ 113°F)
- x **Storage temperature:** -20° ~ 60°C (-4° ~ 140°F)
- x **Relative humidity:** 10% ~ 90% @ 40°C, non-condensing
- x **Shock (operation):** 10 to 25Hz(X,Y,Z direction 2G 30minutes)
- x **CE/FCC :** Complies with EN 55022:2006, Class A
EN 61000-3-2:2006
EN 61000-3-3:1995+A1:2001+A2:2005
- x **Front panel meets NEMA4 / IP65**

MT8100i

Dimensions Drawing

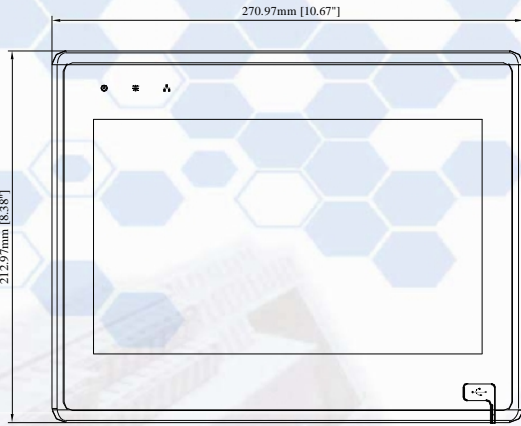

Front View

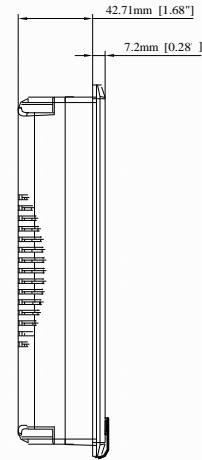

Side View

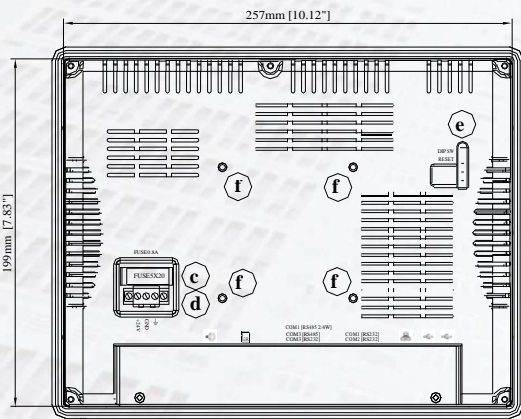

Rear View

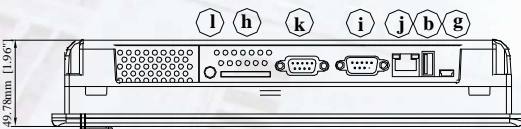

Bottom View

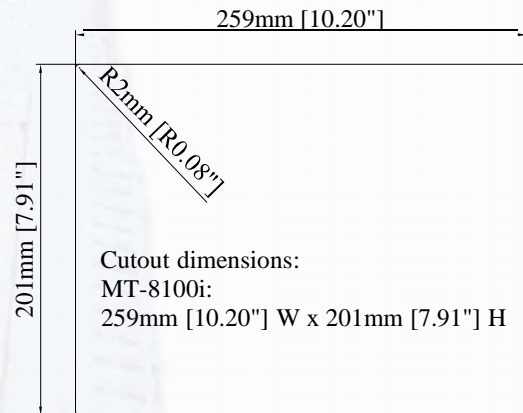

Cutout dimensions:
MT-8100i:
259mm [10.20"] W x 201mm [7.91"] H

1. The "b" USB Host port can be connected alternatively from the USB port on the front panel.

a	N/A	f	VESA 75mm screw holes
b	USB Host port *1	g	USB Device port
c	Fuse	h	SD card slot
d	Power connector	i	Com1 RS232, Com2 RS232
e	DIP SW & Reset button	j	Ethernet port (RJ-45)
l	Line out	k	Com1 RS485, Com3 RS485, Com3 RS232

Ordering Information

% MT8100i:

10" 800x480 TFT LCD HMI, 128MB flash memory/64MB DDR2 RAM on board.

% RZCMT6100:

MT6000/8000 i series download cable / Mini USB to USB 2.0 100 cm

% RP0081000

10" Protective Sheet, for MT610i, MT6100i, MT8100i

<http://www.aptus-hmi.com/>

Ctra.de Ribes,195 - 08520 LES FRANQUESES DEL VALLES (Barcelona – Spain)

Telf. + 34 93 840 25 24 - Fax + 34 93 8402503 - weintek@aptus-hmi.com