

# SBC



## PSB-701LF

Socket 775 Intel® Core 2 Duo/ Core 2 Quad  
PICMG 1.3 CPU Card w/  
VGA/Sound/2LAN

### Features and Benefits:

- Support Intel® Core 2 Quad, Core 2 Duo and Celeron® processors
- Equipped with Intel® Q35 Chipset with FSB 800/1066/1333MHz
- Memory Supports DDRII 667/800 SDRAM up to 4GB
- Supports 2 x 10/100/1000 Mbps Ethernet Connection, PICMG 1.3 compliance
- Supports Intel AMT 3.0
- Supports Trusted Platform Module Applications such as ATM, multimedia systems, digital image storage servers and more



**PROTECH SYSTEMS**

*It's the right choice*

No. 24, Lane 365, Yang Guang St., Nei Hu District, Taipei 114, Taiwan, R.O.C.

Tel: +886-2-8751-1111

Fax: +886-2-8751-1199

Email: [sales@protech.com.tw](mailto:sales@protech.com.tw)

<http://www.protech.com.tw>



ISO CERTIFIED

9001 14001

# PSB-701LF

Socket 775 Intel® Core 2 Duo/ Core 2 Quad PICMG 1.3  
CPU Card w/ VGA/Sound/2LAN

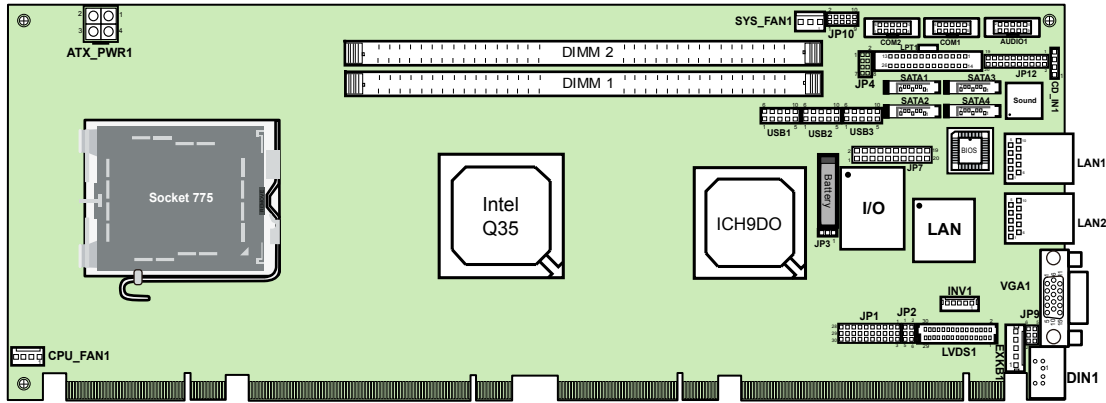

## Specifications

<b>System</b>	
<b>CPU Type</b>	Intel® Core 2 Quad/ Core 2 Duo/ Celeron CPU with LGA775 CPU socket. (support Intel 65nm, 45nm Process Technology CPU)
<b>CPU Frequency</b>	Core 2 Quad: 2.4~2.66GHz Core 2 Duo: 1.8~3.0GHz Celeron: 1.6~2.0GHz
<b>Chipset</b>	Intel® Q35 + ICH9DO (FSB: 800/1066/1333MHz)
<b>DRAM</b>	2 x 240-Pin DDR2 DIMM, support Dual channel memory architecture and DDR2 667/800MHz up to 4GB
<b>BIOS</b>	Phoenix-Award PnP BIOS, with 32MB SPI flash
<b>Watchdog</b>	1~255 secs Watchdog timer selectable Clear/Reset/NMI
<b>Power Supply</b>	Support ATX power
<b>Power Requirement</b>	+5V, +12V, +3.3V, +5Vsb
<b>Power Consumption</b>	+5V:3.3A, +12V:5.63A, +3.3V:1.64A, 5VSB:0.26A (USE INTEL CORE 2 QUAD Q6700 2.66GHz)
<b>Dimension</b>	338.5 mm x 126 mm (13.33" x 4.96")

## I/O Chipset

<b>SATA Interface</b>	4 x S-ATA II connector (Raid 0,1,10,5)
<b>TPM</b>	TPM1.2 1 with 20-pin header on board for TPM (Trusted Platform Module)
<b>Serial Port</b>	2 x COM ports, COM1 for RS232, COM2 for RS232/422/485 (for 16550 compatible type of UART)
<b>Keyboard</b>	Mini DIN connector or external connector
<b>Mouse</b>	Mini DIN connector or external connector

<b>LAN</b>	LAN 1: Intel® 82566DM (10/100/1000 Mbps) LAN 2: Intel® 82573L (10/100/1000 Mbps) Support Wake-on-LAN with ATX power Support iAMT 3.0
<b>Audio</b>	High Definition Audio Realtek ALC262A with 10-pin header for Line-in/Line-out/MIC
<b>USB</b>	6 x USB 2.0
<b>Display</b>	
<b>Graphic</b>	Built-in Intel® Q35, share system memory support CRT, LVDS (LVDS transfer from SDVO)
<b>LCD Interface</b>	18/24-bit LVDS
<b>Environment</b>	
<b>Operation Temp.</b>	0°~60°C(32°~140°F)
<b>Storage Temp.</b>	-40°~85°C(-40°~185°F)
<b>Humidity</b>	Operation humidity 20~90%, Storage humidity 20~95%

## Ordering Information

<b>PSB-701LF</b>	PICMG 1.3 Intel® LGA 775 CPU w VGA/ SATA/ Audio/ LAN(1G)/2 x COM (RoHS)
------------------	--

**Certificate: CE, FCC CLASS A**

All of trademarks and brand names are the property of their owners. Trademark "Protech" is the property of Protech Systems Co., Ltd.  
All information contained in this document is subject to change without any prior notice. This catalog is copyrighted in May 2008.