

# TCS - TCE

## Temperature Controllers

- Self-tuning PID algorithm
- Intuitive color display with text messaging
- Universal process and TC/RTD inputs
- Multi-function ramp-dwell/process timer
- Soft start output power limiter
- Up to 4 control and alarm outputs
- Load current display and fault monitor
- Up to 3 Logic inputs
- Serial ModBus communications option
- OPC based graphical configuration software
- IP 65 and NEMA 4X front protection
- Digital retransmission
- Up to 5 recipes
- Up to 3 analog outputs
- Transmitter power supply (TCE only)



### Overview

The new TCS (1/16th DIN) and TCE (1/8th DIN) controllers provide a new level of user convenience. Fully configurable scrolling text provides indication of exactly what is happening in the process.

### Operation Interface

The new three color display provides clear indication of process variables. The upper display shows the process value while the lower display can be set to indicate a range of parameters including, setpoint, time remaining and load current. The operator interface is fully customizable enabling any parameter to be promoted for immediate operator access. Scrolling text display messages may be up to 127 characters in length. The TCE provides additional graphic analog indication of OP power, error and heater current.

### Quick Set-Up

The Quick Start instrument set up code makes configuration quick and simple. At initial power up the configuration is displayed on the lower display as an 8 character code that presets all main controller functions.

### Universal Inputs

The Universal process and temperature input enables simple selection of standard thermocouple, RTD or mA/V process input types. Custom sensor/ input linearizations may be loaded using PC based configuration software.

### Load Current Transformer Input

The Load Current Transformer (CT) Input monitors current flowing in the controlled load and provides immediate indication of load fault conditions. Load failure indication, heater open circuit or Solid State Relay (SSR) short circuit can each be indicated by clear scrolling operator messages and relay alarm output.

### Communication Options

The communication options provide full integration with PLC, SCADA and DCS systems using industry standard ModBus protocol. Optional RS232 or RS485 interfaces are also available.

### Configuration Port

The CPI configuration interface provides direct connection between a host PC RS232 or USB interface and the instrument without the necessity of fitting a communication option. The CPI configuration interface is a standard feature of both the TCS and TCE instruments.

#### Configuration Wizard

Graphical PC based Dynisco set-up software provides a step by step guide to setting up all instrument functions, simplifying the configuration procedure. The CPI configuration interface and set-up software enables complete instrument configurations to be copied and stored between the instrument and a host PC.

#### Recipes

38 parameter values may be stored in 5 separate recipe memories, each with a customer defined name. Applications include storing multiple configurations and holding multiple ramp-dwell programs. Recipes may be selected either as a user interface option, logic input selection or communication parameter setting.

#### Zone Control Master

The master communication feature allows the TCS and TCE to transmit setpoints to slave units for multi zone control applications. Up to 32 slaves may be connected.

#### Timer Functions

Timer functions offer the choice of: dwell timer; a delayed switch on timer or a soft start output power limit timer. A Logic input provides external control or timer function or Set point selection

#### Dwell timer example

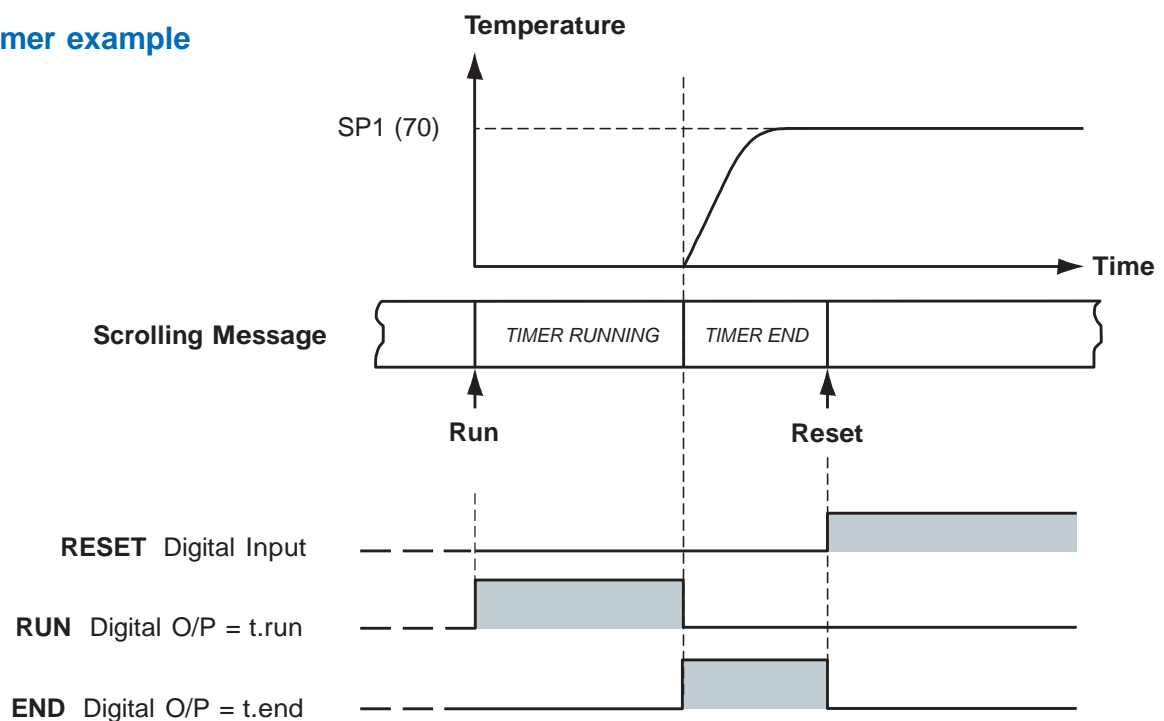

### General Specifications

<b>Sleeve:</b>	ABS
<b>Self-extinguishing degree:</b>	V-0 according to UL 746C
<b>Front protection:</b>	IP 65 and NEMA4X for indoor location according to IEC 529, CEI 70-1 and NEMA 259-1991
<b>Weight:</b>	250 g max
<b>Power supply:</b>	- from 85 to 260V AC 50/60Hz - 24 V AC/DC
<b>Power consumption:</b>	5 W max
<b>Isolation resistance:</b>	2300 V RMS (EN61010-1)
<b>Sampling time:</b>	250 ms
<b>Accuracy:</b>	+ 0.25% of reading.
<b>Electromagnetic compatibility:</b>	this instrument is marked CE
<b>Installation category:</b>	II
<b>Thermal drift:</b>	< 100 ppm/°C of the input span for TC inputs < 120 ppm/°C of the input span for RTD input
<b>Operative temperature:</b>	from 0 to 55 °C. (23 to 131 °F)
<b>Storage temperature:</b>	from -20 to +85 °C
<b>Humidity:</b>	from 5 % to 90% RH, non condensing

### Control Action

<b>Standard algorithm:</b>	ON-OFF, PID with self-tuning function, one (heat or cool) or two (heat and cool) control outputs
<b>Local set points:</b>	2 local set point selectable + digital remote selectable set point

### Analog Inputs

#### Thermocouples

<b>Engineering units:</b>	°C, °F, °K, % or none
<b>Cold junction:</b>	automatic compensation from 0 to 55 °C
<b>Cold junction compensation error:</b>	>0.033 °C/°C
<b>TC type:</b>	J, K, N, T, L, R, S, B + custom

#### RTD

<b>Type:</b>	Pt 100 3 wires
<b>Line resistance:</b>	automatic compensation up to 20 W/wire
<b>Engineering units:</b>	°C, °F, °K, % or none.
<b>Burn out:</b>	the instrument detects the open condition of one or more wires and the short circuit of the sensor

#### Standard range table

TC type	°C	°F
B	0/1820	32/3308
L	-150/900	-238/1652
J	-150/1200	-238/2192
K	-150/1370	-238/2498
N	-150/1300	-238/2372
R	-50/1768	-58/3214
S	-50/1768	-58/3214
T	-150/400.0	-238/752

RTD type	°C	°F
Pt 100	-200/850	-328/1562

## Linear Inputs

*Type:* from -10 to 80 mV,  
0-20 mA, 4-20 mA

*Read-out:* from -1999 to 9999 with decimal point

*Input impedance:* > 1 MW for mV input  
< 3 W for mA input

## Current Transformer Input

*Input type:* from 0 to 50 mA RMS 50/60 Hz (sine wave)

*Input impedance:* < 20 W

*Resolution:* - 0.1 A up to 10 A  
- 1 A up to 100 A

## Outputs

### Relay

*Function:* control output, alarm or event

*Relay type:* (OP 1,2,3) form A (OP 4) form C

*Contact rating:* 2 A @ 250 V AC on resistive

### Logic outputs

*Function:* control output, alarm or event

*Logic voltage:* output not isolated.  
- level 1: 12 V DC @ 40 mA max  
24 V DC @ 1 mA  
- level 0: < 0.5 V DC

## Linear mA Output

### Output 1 and 2

*Type:* 0-20 mA or 4-20 mA not isolated

### Output 3 (TCE only)

*Type:* 0-20 mA or 4-20 mA isolated (60V RMS)

*Function:* heating, cooling or retransmission

*Maximum load:* 500 W

## Transmitter power supply (TCE only)

*Voltage:* 24 V DC

*Current:* max. 30 mA

## Alarms

### Alarms on the measured value

<b>Type:</b>	- process - band - deviation
<b>Action:</b>	direct or reverse
<b>Reset:</b>	automatic or manual
<b>Mask:</b>	masked alarm or standard
<b>Histeresys:</b>	in engineering units

### Heater break-down alarm

<b>Operative mode:</b>	- minimum alarm during the ON period - maximum alarm during the OFF period - over current alarm
<b>Threshold:</b>	independent

## Logic Inputs

<b>Functions:</b>	- set point select - timer Start/stop/reset - manual mode - alarm acknowledge - keyboard lock - output power limiting - recipe selection
<b>Input type:</b>	contact closure voltage free

## Communication Interface

<b>Type:</b>	- factory comm. (standard) - RS-232 (ModBus) - RS-485 (ModBus)
--------------	--

## Timer Function

<b>Type:</b>	- soak on SP1 - delay - soft start
--------------	--

## Recipe Function

<b>Number:</b>	5 max
<b>Parameters stored:</b>	38 max

**Panel Cut - Out (TCS - TCE)**

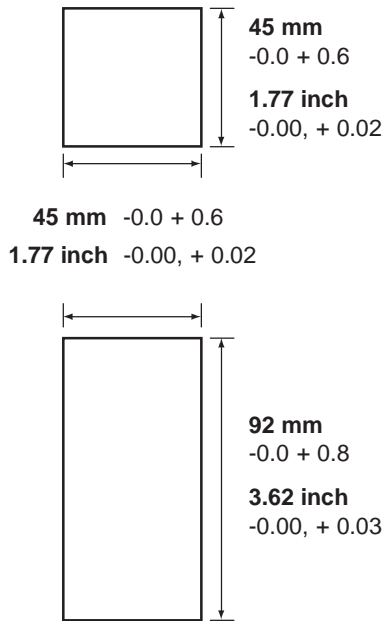

**Recommended Minimum Spacing of Controllers**

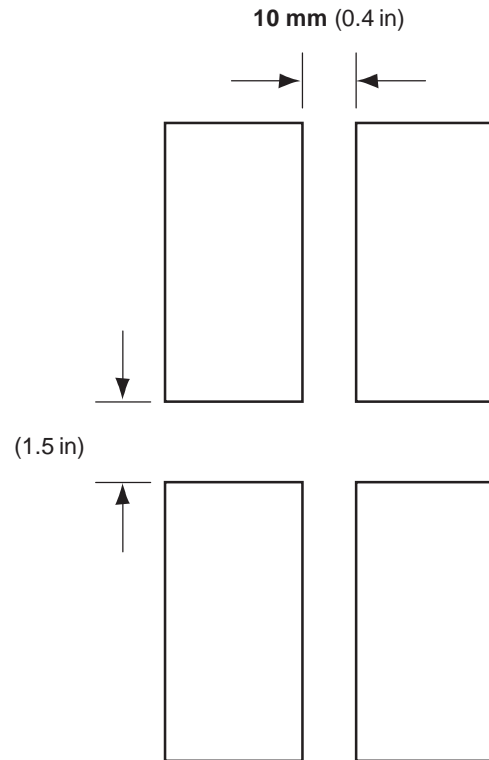

**Dimensions (TCS - TCE)**

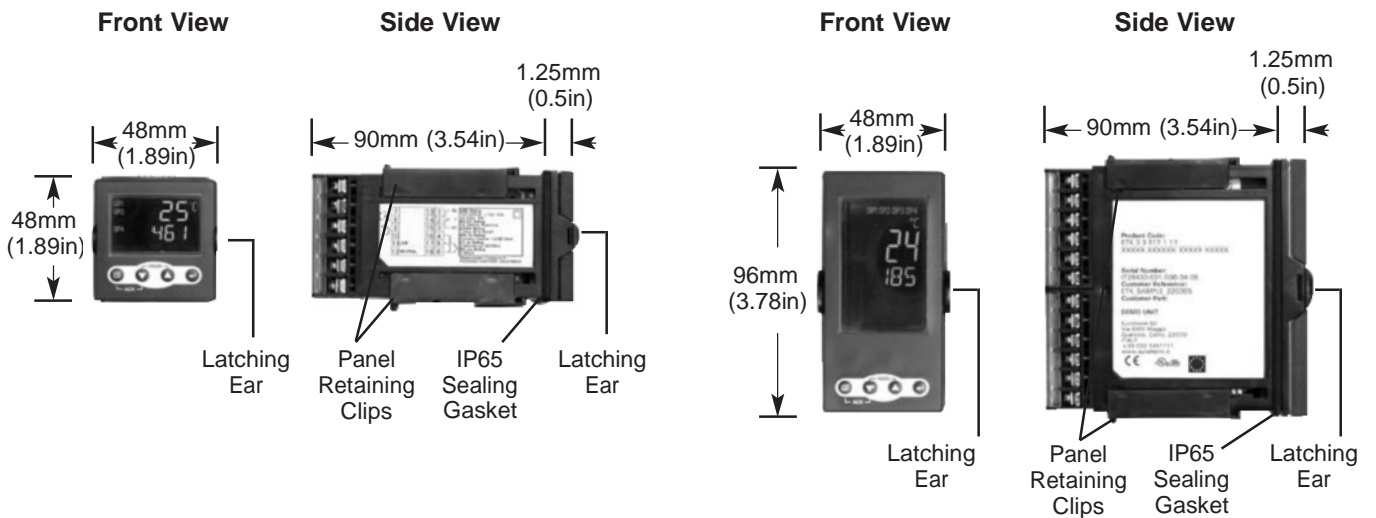

How to Order [TCS -TCE]

MODEL	FUNCTION	PWR SUPPLY	I/O 1	OP 2	OP 3 (TCE ONLY)	OP 4	CT + LOGIC IP	COMS	LANGUAGE
TCS	3 PID – ON/OFF	3 100 – 240 VAC	1 Relay (form A)	0 Not Fitted	0 Not Fitted	0 Not Fitted	0 Not Fitted	0 Not Fitted	E English
TCE**		5 20 – 29 AC/DC	*5 Logic I/O	1 Relay (form A)	1 Relay (form A)	1 Relay (form C)	1 CT + Logic Input	1 RS 232	I Italian
			*7 Linear Out	*6 Logic Out (SSR)	*6 Logic Out (SSR)			2 RS 485	G German
				*7 Linear Out	7 Linear Out (isolated)				F French
									S Spanish

Note

Available OP 1, OP 2, OP3 option combinations: 110 - 111 - 500 - 560 - 511 - 561 - 567 - 517 - 577 - 117 - 717.

(\*) This output is not electrically isolated from the measurement input.

(\*\*) OP 4 options are only available on model TCE.

Rear Terminal Block TCS - TCE

